

SCHEMATIC FOR A HARD-WIRED POWER-OVER-ETHERNET SYSTEM

For typical supply of 7V to 18V @ 1 A - Max 48V @ 2A

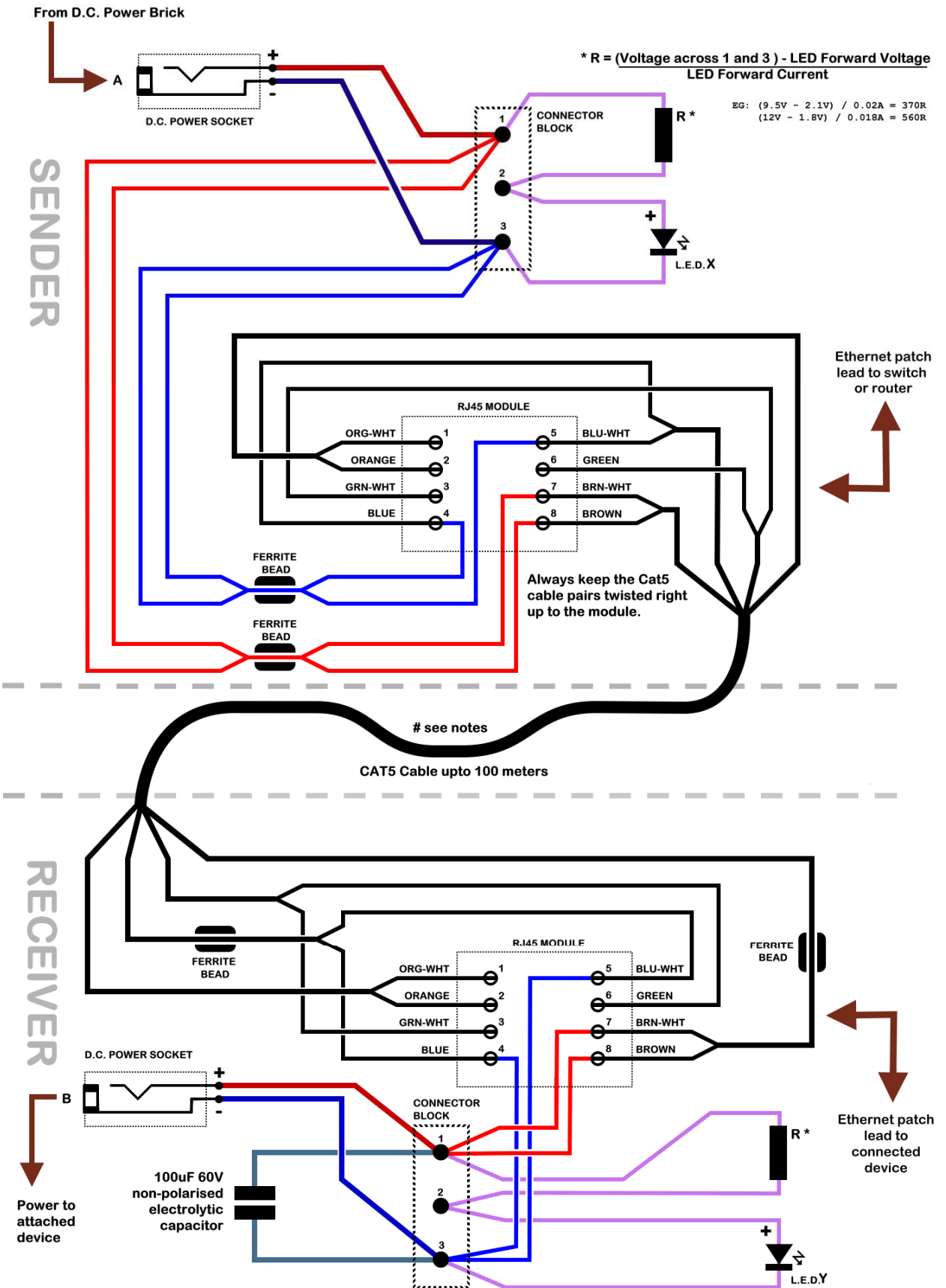

(c) AJB 2008
 Free to reproduce and distribute
 No warranties
 Check values
 Respect Electricity

VOLTAGE DROP = LOAD CURRENT AT B [+ LED CURRENT] x Length in Meters x 0.09
 VOLTAGE AT B = VOLTAGE AT A - VOLTAGE DROP
 DISSIPATION PER METER = (VOLTAGE DROP x LOAD CURRENT AT B) / Length in Meters

EG: For a 12 Volt supply driving a camera with a load of 580 millamps over 25 meters
 $V.DROP = 580mA(I_{camera}) + 20mA(I_{ledX}) + 20mA(I_{ledY}) \times 25m \times 0.09 \approx 1.395V$
 $V.B = 12V(V.A) - 1.395V(V.DROP) \approx 10.6V$
 $W_{meter} = (10.6(V.B) \times 580mA(I_{camera}) + 20mA(I_{ledY})) / 25m \approx 0.255W \text{ per meter}$